



DUE+2 EASY

Wineemotion's DUE+2 dispensing system is designed to the standards demanded by commercial bars and restaurants with a clean, modern look simplifying the way wine is stored and served. This compact, flexible system is intended for behind the bar use. Its sleek stainless-steel finish is not only elegant but durable, sanitary, and built to withstand the rigors of a high-traffic environment. Our commitment to using highest quality materials assures colder wine temperatures, hassle-free operations and years of trouble-free service.

PRODUCT FEATURES

❖ Temperature Range

- ▶ Dual Zone: 42-70°F for 2 Reds + 2 Whites or 4 Red Wines.

❖ Refrigeration

- ▶ Silent, industrial compressor enables ideal temperature storage for any wine varietal.
- ▶ Fan-forced front exhausting allows for easier built-in installations. Zero ventilation or drainage requirements.

❖ Usage Configuration

- ▶ Behind the Bar (for Staff Use).

❖ System Control

- ▶ Electronic key and dispensing lock activated by 4-digit PIN code.

❖ Portion Control

- ▶ 3 programmable portions from 0.5 to 9 oz.

❖ Preservation

- ▶ 30-Day Advanced Wine Preservation with Food Grade Argon or Nitrogen Gas (99.99% Purity).
- ▶ External Gas Tank Required.

❖ Display

- ▶ Central LCD display to access the technical menu.
- ▶ Energy saving feature with sleep mode and sensor wake-up.

❖ Finish

- ▶ Commercial-grade all stainless-steel interior and exterior provide superior durability and easy cleaning .
- ▶ Optional RAL Color Customization in Matte or Gloss Finish.

❖ Bottle Lifting System

- ▶ Manual gas spring pistons for fast and easy bottle changes.
- ▶ Ability to load any bottle size: 375mL to 750 mL.
- ▶ Fail-Safe functionality keeps bottles pressurized even when running out of gas.

❖ Doors

- ▶ Double pane, UV tinted thermal glass doors, the latest in energy efficient technology.

❖ Lighting

- ▶ LED lighting to gently illuminate the labels.

❖ ISOL-PLUS Technology

- ▶ Patented unique valve which prevents aromatic cross-contamination of wines in the same unit.

❖ AUTO-PUFF Valve

- ▶ Patented valve technology which automatically cleans the spout after each pour ensuring maximum freshness

❖ OSHA Compliant

- ▶ ETL certified for safety (conforms to UL).
- ▶ ETL sanitation (conforms to NSF).

❖ Warranty

- ▶ Industry-leading 2-year warranty for owner's ease of mind.

Models	Width	Height	Depth	Weight	Electrical Requirements
DUE+2 Dual Temperature	20.79 in.	25.00 in.	15.75 in.	95 lbs	110VAC 60Hz – 2A

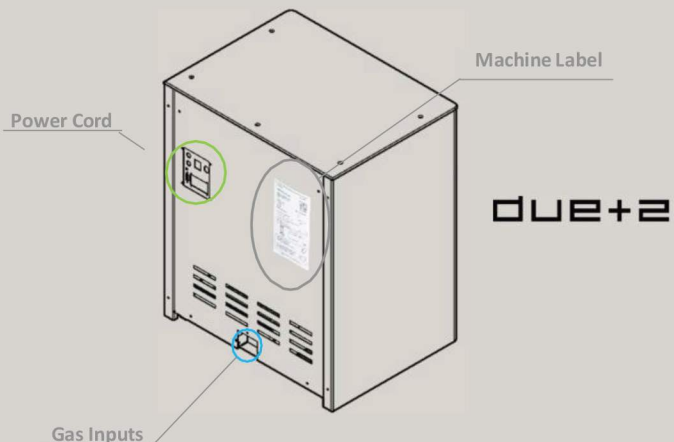
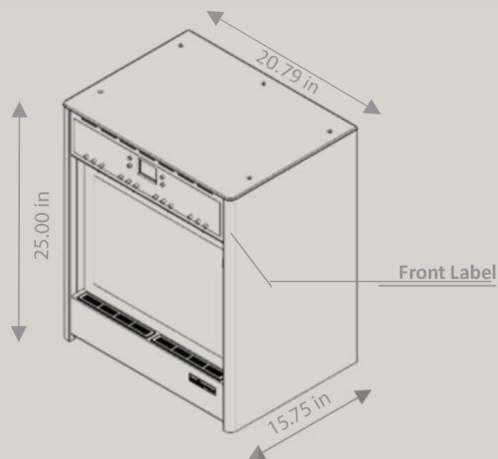

SPACE REQUIREMENTS

US PLUG SPECS

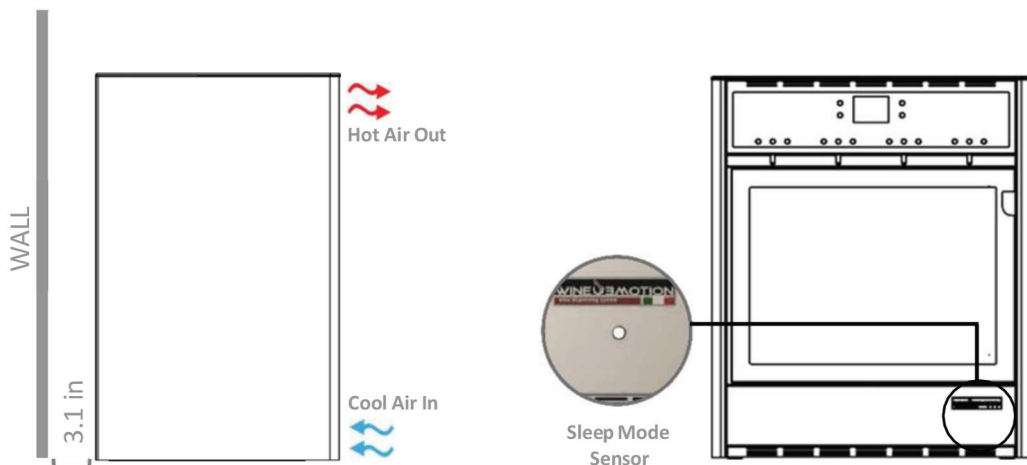

NEMA RECEPTACLES 5-15r



TECHNICAL SPECIFICATIONS

WIDTH	<u>20.79 in</u>
HEIGHT	<u>25.00 in</u>
DEPTH	<u>15.75 in</u>
WEIGHT CT	<u>95 lb</u>

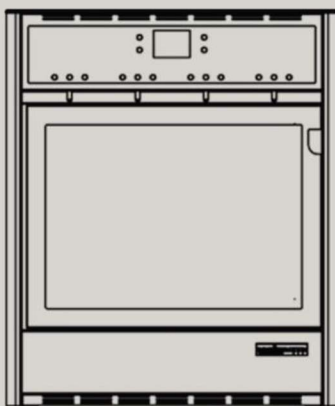

TEMPERATURE COMBINATIONS



CERTIFICATIONS

USA 110VAC 60Hz

NSF 25 UL 751 UL 541

