



DUE+2-PRO

Wineemotion's DUE+2 PRO dispensing system is designed to the standards demanded by commercial bars and restaurants with a clean, modern look simplifying the way wine is stored and served. This compact, flexible system can be utilized for either behind the bar or for customer's use. Its sleek stainless-steel finish is not only elegant but durable, sanitary, and built to withstand the rigors of a high-traffic environment. Our commitment to using highest quality materials assures colder wine temperatures, hassle-free operations and years of trouble-free service.

PRODUCT FEATURES

❖ Temperature Range

- Dual Zone: 42-70°F for 2 Reds + 2 Whites or 4 Red Wines.

❖ Refrigeration

- Silent, industrial compressor enables ideal temperature storage for any wine varietal.
- Fan-forced front exhausting allows for easier built-in installations. Zero ventilation or drainage requirements.

❖ Usage Configuration

- Behind the Bar (for Staff Use).
- Self-Service with Wine Cards & Software.

❖ System Control

- Key Card Activation to control pours and lock the front door.

❖ Portion Control

- 3 programmable portions from 0.5 to 9 oz.

❖ Preservation

- 30-Day Advanced Wine Preservation with Food Grade Argon or Nitrogen Gas (99.99% Purity).
- External Gas Tank Required.

❖ Display

- Customizable colored LCD displays featuring wine information and portions. Card balance and pricing shown with Software.
- Energy saving feature with sleep mode and sensor wake-up.

❖ Bottle Lifting System

- Automated pistons for fast and easy bottle changes.
- Ability to load any bottle size: 375mL to 750 mL.
- Fail-Safe functionality keeps bottles pressurized even when running out of gas.

❖ Doors

- Double pane, UV tinted thermal glass doors, the latest in energy efficient technology.

❖ Lighting

- RGB lighting to gently illuminate the labels with 14 different color options at the push of a button.

❖ Finish

- Commercial-grade all stainless-steel interior and exterior provide superior durability and easy cleaning .
- Optional RAL Color Customization in Matte or Gloss Finish.

❖ ISOL-PLUS Technology

- Patented unique valve which prevents aromatic cross-contamination of wines in the same unit.

❖ AUTO-PUFF Valve

- Patented valve technology which automatically cleans the spout after each pour ensuring maximum freshness

❖ OSHA Compliant

- ETL certified for safety (conforms to UL).
- ETL sanitation (conforms to NSF).

❖ Warranty

- Industry-leading 2-year warranty for owner's ease of mind.

Software Activated Systems Only

❖ Data Connection

- LAN Network (Recommended) or Wi-Fi.

❖ Integrations

- POS, Hotel Room Key, Barcode, and Magnetic Strip Integrations are available.

Models	Width	Height	Depth	Weight	Electrical Requirements
DUE+2 PRO Dual Temperature	20.79 in.	25.00 in.	15.75 in.	95 lbs	110VAC 60Hz – 2A

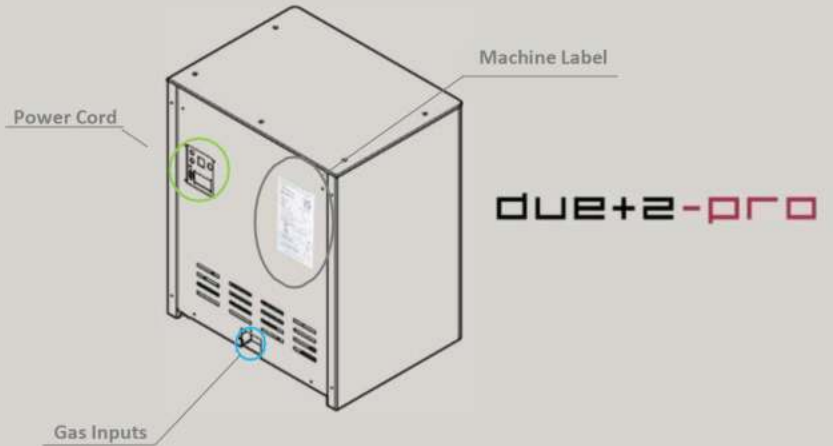
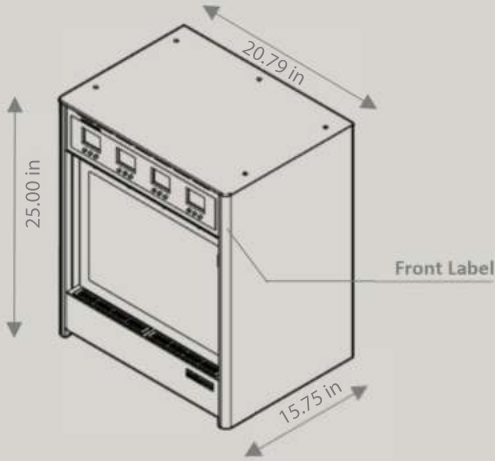

due+2-pro

SPACE REQUIREMENTS

US PLUG SPECS

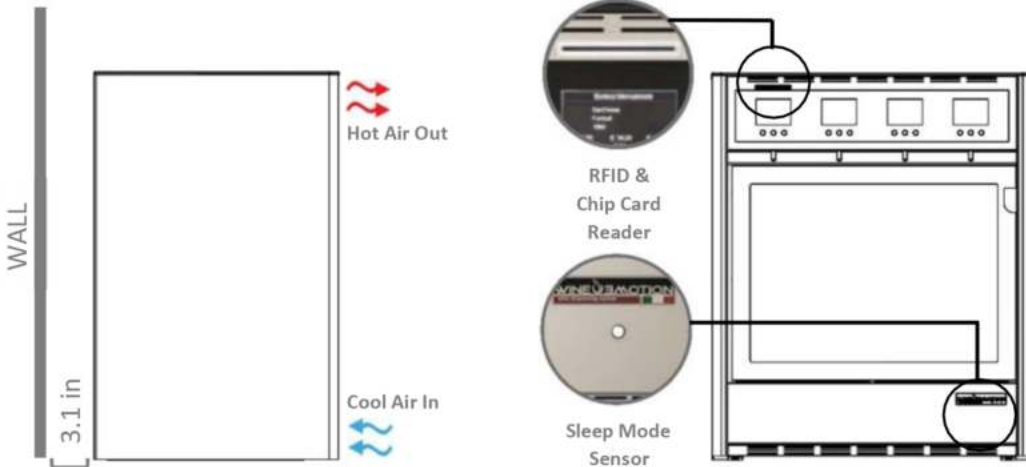

NEMA RECEPTACLES 5-15r



TECHNICAL SPECIFICATIONS

WIDTH	20.79 in
HEIGHT	25.00 in
DEPTH	15.75 in
WEIGHT CT	95 lb

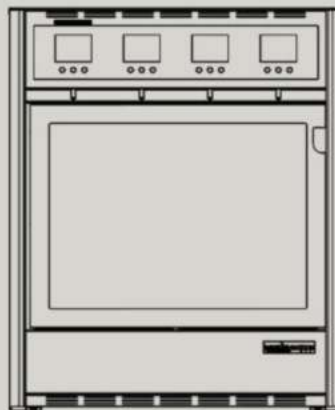

TEMPERATURE COMBINATIONS



CERTIFICATIONS

USA 110VAC 60Hz

NSF 25 UL 751 UL 541

